

DIVIDER startup

Adapts to your requirements

Ideal for your canteen, commercial kitchen, butcher's shop or convenience production. The **DIVIDER startup** entry level model provides you with a flexible basis.

The DIVIDER startup stands out on account of its **mobility** and high level of adaptability. The **compact design** and **space saving installation** allow **flexible solutions** every day. The DIVIDER startup cleverly combines optimised handling through **intuitive operation**, the proven TREIF slicing technology and the **hygiene design**.



Flexible, space saving and reliable, while the low weight and mobile base allow you to **move and set up** the slicer just as needed.



The blade slider prevents stopping of the blade to ensure an **extremely short product loading time - minimising dead time**.



The **intuitive, menu guided operation with touch display and intelligent assistance function** allows users to **change products in a matter of seconds**. Data transfer via USB port, e.g. for import or data backup.



Whether cheese, cold meats or convenience products - a variety of **product presentations** can be sliced with the DIVIDER startup, e.g. fan, stack, zig-zag.



Large chamber in a small space - the DIVIDER startup allows you to process several products in just one slicing process.



With the circular blade slicer DIVIDER startup you can slice a wide range of products without the need to make any conversions to the machine.



The true energy saver: your slicer

A slicer that goes easy on the environment - and on your costs!

The DIVIDER startup allows products to be sliced at higher temperatures. That **saves time** for cooling and **costs by minimising energy input**.

Pretty clever, right? That is slicing with TREIF!

Technical data:

Max. cut-off length (mm/inch)	0.5-25; 1/50"-1"
Max. cuts/min. (theoretical maximum value)	900
Max. infeed length (mm/inch)	600; 23 5/8"
Cross section of product w x h (mm/inch)	280x160; 11" x 6 3/10"
Max. stacking height (mm/inch)	50; 2"
Housing dimensions (mm/inch)	
Length with outlet conveyor / Width (mm/inch)	2,400 / 940; 94 1/2" / 37"
Transport / Set-up height (mm/inch)	1,850 / 1,990; 72 53/64" / 78 11/32"
Connecting load (kW)	2.8
Weight (kg/lb)	approx. 560; 1,235
Product specific accessoires	on request

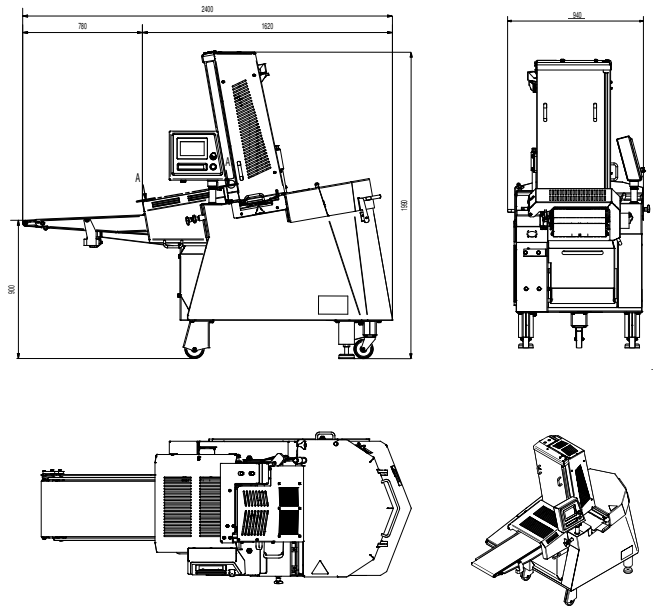

Zig-zag stacks - another option offered by the DIVIDER startup.

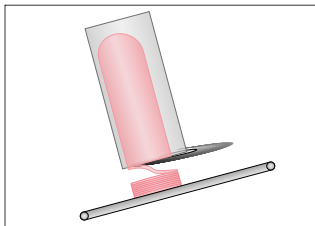

Static Distance Control (SDC): The placement table is positioned before the slicing process for **optimum placement of the slices**.



Use the slicer for stacking your products: up to 50 mm high stacks and 300 cuts per minute are possible.

Your benefits at a glance:

- **Product flexibility:** Slicing at **premium level** - no conversion for product changes
- **Mobility:** **Demand-based installation** thanks to low weight and easy transport
- **Low maintenance effort**
- **Fast and easy cleaning** thanks to the proven **premium hygiene design**
- All benefits of the proven slicer generation from TREIF: even more power and dynamics in the drives, even shorter ancillary times, **maximum process reliability**, more capacity, more flexible reactions to customer requests
- Also ideal for processing **vegetarian products**
- **Simultaneous slicing of multiple products** - even different types
- **Convenience:** user friendly **software with touch display**

HEADQUARTERS:

TREIF Maschinenbau GmbH
Toni-Reifenhäuser-Str. 1
D-57641 Oberlahr
Tel. +49 2685 944 0
Fax +49 2685 1025
E-Mail: info@treif.com

USA:

TREIF USA Inc.
50 Waterview Drive, Suite 130
USA-Shelton CT 06484
Tel. +1 203 929 9930
Fax +1 203 929 9949
E-Mail: treifusa@treif.com

United Kingdom:

TREIF U.K. Ltd.
Genesis House, Poole Hall Road,
Poole Hall Industrial Estate
Ellesmere Port, GB-Cheshire CH66 1ST
Tel.: +44 (0) 151 3506100
Fax: +44 (0) 151 3506101
E-Mail: treifuk@treif.com

Other locations:

Italy

France

Belgium

Poland

China